

**Contents of the pack - Obsah balenia:**

#### EN - CE DECLARATION OF CONFORMITY

**Note:** The text herein has been adapted to meet editorial requirements. A copy of the original declaration may be requested from Nice S.p.a. (TV) I.

Declaration number: **512/AGIO**; rev.: **0**; Language: **EN**

The undersigned Mauro Sordini, in the role of Chief Executive Officer of NICE S.p.A. (via Pezza Alta no. 13, 31046 Rustigné di Oderzo (TV), Italy), declares under his sole responsibility that the products AG4BB, AG4BW, AG4BR, AG4B, AG4W, AG4R, conform to the essential requirements stated in the European directive 1999/5/CE, for the intended use of products. In accordance with the same directive (appendix V), the product is class 1 and marked **CE 0682**

Mr. **Mauro Sordini** (Chief Executive Officer)

#### SK - VYHLÁSENIE O ZHODE ES

**Poznámka:** Tu uvedený text bol upravený z tlačových dôvodov. Kópiu pôvodného vyhlásenia si môžete vyžiadať v Nice S.p.a. (TV) Taliansko.

Číslo vyhlásenia: **512/AGIO** ; rev.: **0** ; Jazyk: **SK**

Dolupodpísaný Mauro Sordini, vo funkcii generálneho riaditeľa Nice SpA (Via Pezza Alta n° 13, 31046 Rustigné Oderzo (TV), Taliansko), vyhlasuje na svoju vlastnú zodpovednosť, že výrobky AG4BB, AG4BW, AG4BR, AG4B, AG4W, AG4R spĺňajú základné náležitosti komunitárnej smernice 1999/5/ES pre použitie, na ktoré sú zariadenia určené. V súlade s tou istou smernicou (príloha V), výrobok spĺňa požiadavky triedy 1 pre označenie: **CE 0682**

Ing. **Mauro Sordini** (generálny riaditeľ)

#### IT - DICHIARAZIONE CE DI CONFORMITÀ

**Nota:** Il testo qui presente è stato riadattato per motivi editoriali. Copia della dichiarazione originale può essere richiesta a Nice S.p.a. (TV) I.

Numero dichiarazione: **512/AGIO**; rev.: **0**; Lingua: **IT**

Il sottoscritto Mauro Sordini, in qualità di Amministratore Delegato della NICE S.p.A. (via Pezza Alta n°13, 31046 Rustigné di Oderzo (TV) Italy), dichiara sotto la propria responsabilità che i prodotti AG4BB, AG4BW, AG4BR, AG4B, AG4W, AG4R, risultano conformi ai requisiti essenziali richiesti dalla direttiva comunitaria 1999/5/CE, per l'uso cui gli apparecchi sono destinati. In accordo alla stessa direttiva (allegato V), il prodotto risulta di classe 1 e marcato **CE 0682**

Ing. **Mauro Sordini** (Amministratore Delegato)

#### DE - CE-KONFORMITÄTSERKLÄRUNG

**Hinweis:** Der hier aufgeführte Text wurde aus Verlagsgründen angepasst. Eine Kopie der ursprünglichen Erklärung kann bei Nice S.p.a. (TV) Italy angefordert werden.

Nummer der Erklärung: **512/AGIO**; rev.: **0**; Sprache: **DE**

Der Unterzeichnende, Mauro Sordini, im Amte des Chief Executive Officer des Unternehmens NICE S.p.A. (Via Pezza Alta 13, 31046 Rustigné di Oderzo (TV) Italy), erklärt unter seiner Verantwortung, dass die Produkte AG4BB, AG4BW, AG4BR, AG4B, AG4W, AG4R, den grundsätzlichen Anforderungen der europäischen Richtlinie 1999/5/EG für die jeweiligen Anwendungszwecke entsprechen. In Übereinstimmung mit dieser Richtlinie (Anlage V), entspricht das Produkt der Klasse 1 und ist **CE 0682** gekennzeichnet.

Ing. **Mauro Sordini** (Chief Executive Officer)

# AGIO

## Vysielač

€ 0682



Rýchly návod

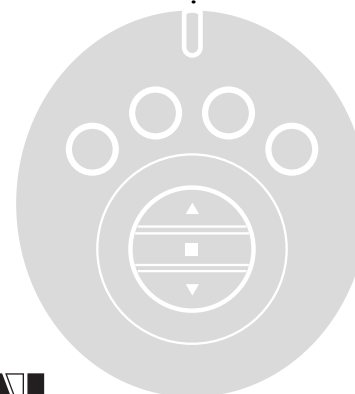

**Nice**  
for  
**FontanaArte**

Nice SpA  
Oderzo TV Italia  
info@niceforyou.com

IS0348A00MMI

**AXIAL**  
automatické brány

**Nice**  
for  
**FontanaArte**

# AGIO

To manage lights,  
electrical loads and automations

For further information on the Agio system  
and Nice connected devices:

[nicelight.niceforyou.com](http://nicelight.niceforyou.com)

*Na ovládanie svietidiel, elektrických  
záťaží a automatických pohonov*

*Bližšie informácie o systéme Agio a  
zapojiteľných zariadeniach Nice:*

[nicelight.niceforyou.com](http://nicelight.niceforyou.com)

## LED

(flashes during a drive:  
low batteries)

*(ak blíká počas aktivácie:  
vybité batérie)*

## Select

connected devices

## Výber

*zapojených zariadení*

▲ **Dimmer + OPEN** automation

**Stmievateľ + OTVOR** pohon

■ **OFF - ON** (store the last used)  
**STOP** automation

**OFF - ON** (zapamätá si  
poslednú použitú hodnotu)  
**STOP** pohon

▼ **Dimmer - CLOSE** automation

**Stmievateľ - ZATVOR** pohon

**Slider** to change, in a continuous  
way or with a touch, the light intensity  
or the position of the automation

**Slider** na zmenu, plynulým spôsobom  
alebo dotykom, intenzity svetla  
alebo polohy automatického pohonu

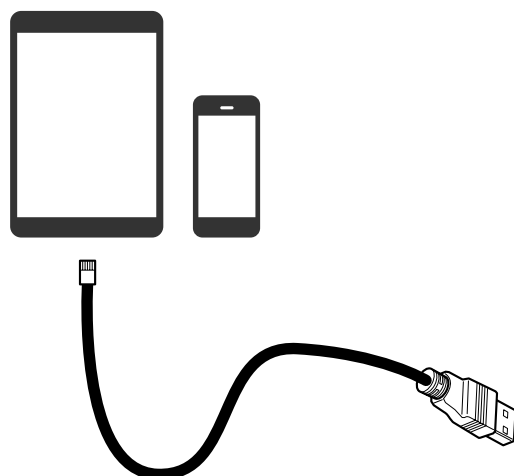
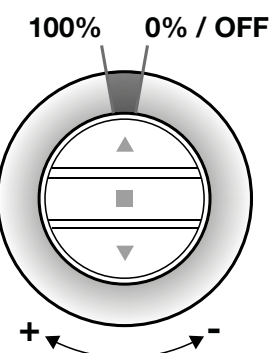

## USB\* jack

5 Vdc MAX - 850 mA

## Konektor USB\*

5 Vdc MAX - 850 mA

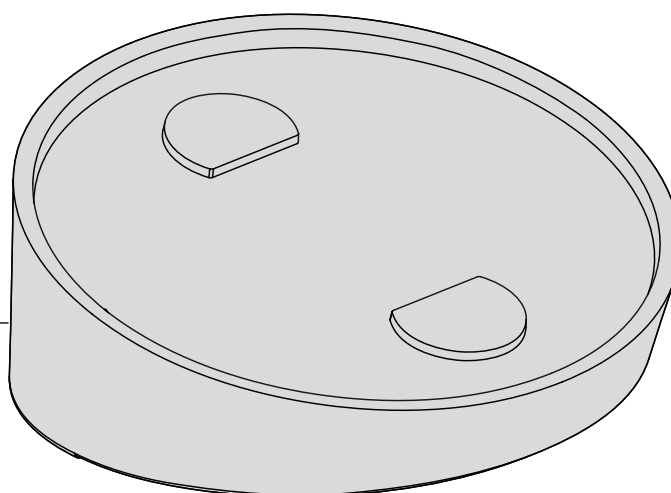
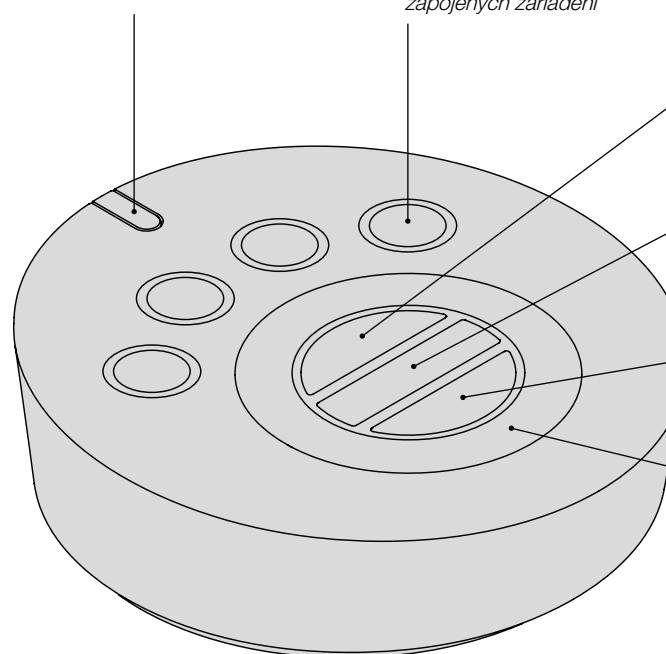

## On/off courtesy light\* On/Off pomocné svetlo\*

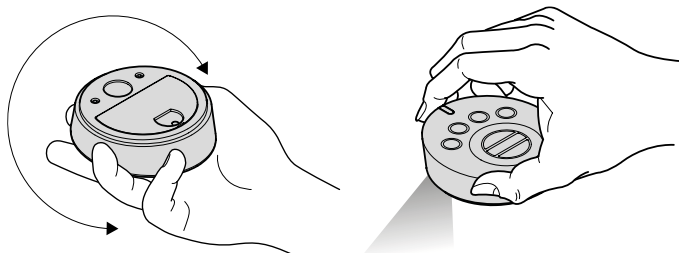

## Wake from standby\* Oživenie z režimu standby\*

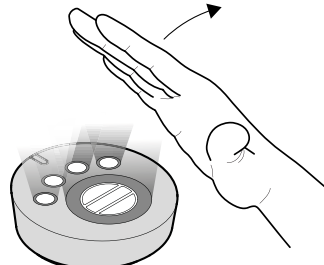

## Wall-mounted\* Upevnenie na stenu\*

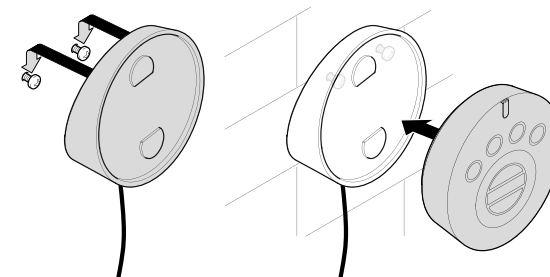

\* AG4B, AG4R, AG4W